

SAMI AUTOSORTER



Instruction manual



Loading table and automatic wood sorter

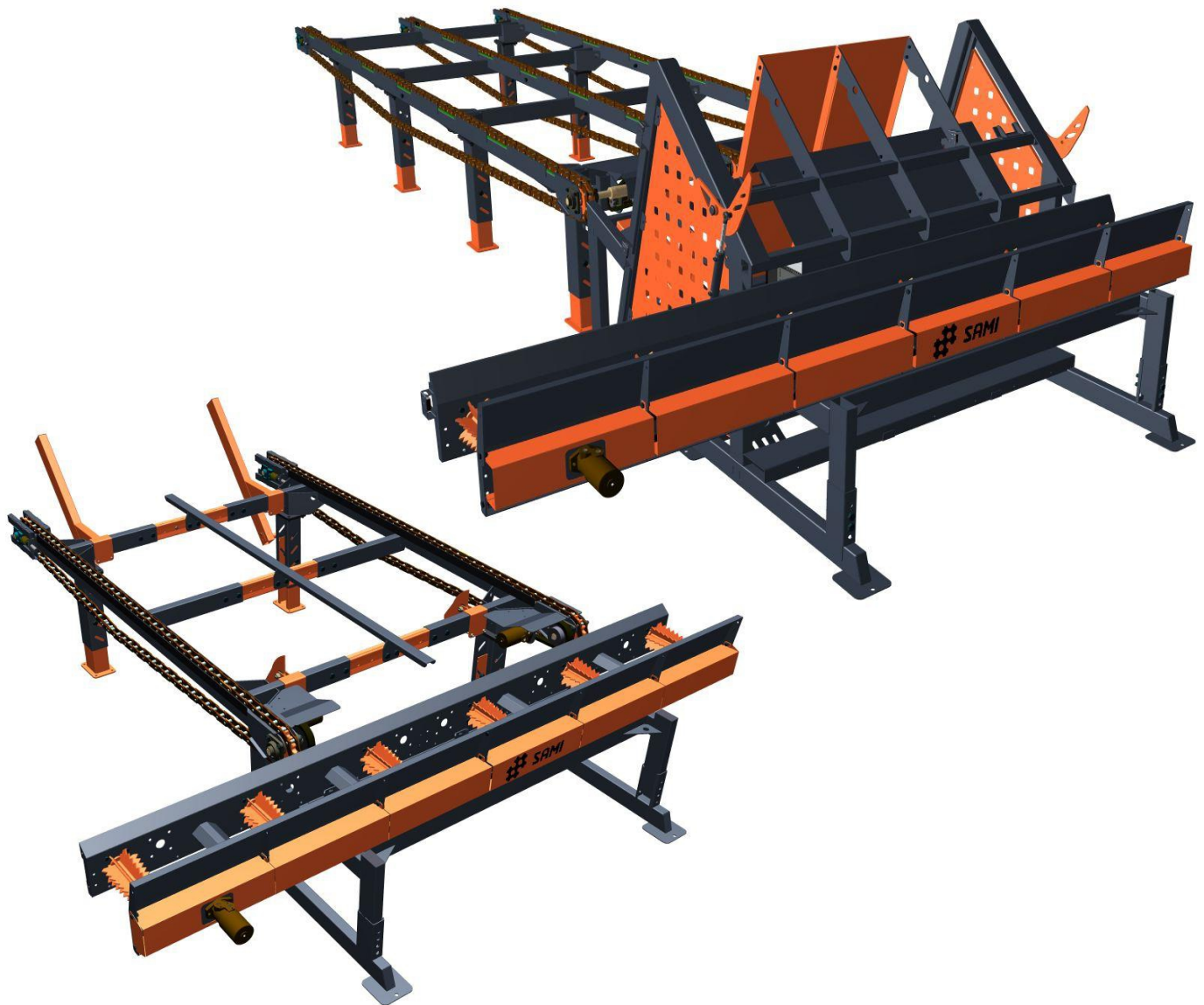

Year of manufacture		 SAMI SAMI-FINLAND.COM
Serial number		
Quality controller signature / date		

VAT -registered: FI-21220619
Factory & office: Kauhava - Finland

Version 1.2.0, updated 18.11.2016

Content

FOR THE OWNER	3
WARRANTY TERMS	4
DECLARATION OF CONFORMITY, SORTER	5
DECLARATION OF CONFORMITY, LOADING TABLE	6
SAFETY	7
WARNING LABELS	9
TYPE PLATES	10
GENERAL DESCRIPTION OF THE MACHINE	11
DESCRIPTION OF THE OPERATION	11
INSTALLATION	
SORTER	14
SORTER PARTS	17
SORTER DIMENSIONS	19
LOADING TABLE	20
LOADING TABLE 6.5 m PARTS	21
LOADING TABLE 3.5 m PARTS	22
LOADING TABLE DIMENSIONS	23
COMBINING THE SORTER AND THE LOADING TABLE	24
USER INTERFACE	25
MANUAL USE DURING THE AUTOMATIC PROCESS	26
HANDLING OIL	27
DECOMMISSIONING THE PRODUCT	27
TROUBLESHOOTING	28
MAINTENANCE	30
MEMO	34

FOR THE OWNER OF THIS SAMI PRODUCT

We would like to thank you for choosing our product.

Please read this instruction manual carefully, as complete knowledge of the machine, the right adjustments and careful maintenance will guarantee user safety and reliable operation.

It is important that you understand everything in this instruction manual. When you follow the instructions of this manual, the machine will serve you correctly for a long time.

We strongly advise you to run your own risk analysis before to use the product.

Keep this manual available to the user at all time.

If you have any question, please contact the supplier of the machine or the manufacturer.

We would like to ask you to return the warranty certificate to your supplier and the manufacturer after reading this instruction manual.

Sincerely yours,

 **REIKÄLEVY**

Ylihärmä, Finland

WARRANTY TERMS

The warranty period is 1 year, however no more than 1,000 hours of use for which the machine is designed.

The warranty period begins from the day the new machine is delivered.

The warranty will cover any manufacturing and material defects. Any damaged parts will be repaired or replaced. If a fault is deemed not to be covered by the warranty, we will charge for the expenses.

Any warranty repairs will not extend the warranty period.

The warranty will not cover any damage caused by faulty installation, use or maintenance (not complying with the instruction manual), excessive loads or normal wear.

The warranty will not cover any indirect expenses, cargo fees, travel expenses, lay days or changes to the original structure of the machine.

Regarding any warranty issues, you should primarily contact the manufacturer of the machine. Any procedures and their expenses must be agreed upon with the manufacturer in advance.

The warranty will become effective when the warranty/registration notification is filled out appropriately and submitted to the manufacturer within 30 days from the delivery. The filled-out notification will make the processing of any warranty-related or other matters easier and faster.

DECLARATION OF CONFORMITY FOR THE MACHINE

Manufacturer: **Reikälevy Oy**
Address: Yrittäjätie 22, 62375 Ylihärmä, Finland
Phone: +358 (0)10 425 8000
Fax: +358 (0)6 484 6251
Website: www.reikalevy.fi

We certify exclusively on our own responsibility that the machine placed on the market:



Automatic wood sorter SAS-W2200, beginning from the serial number ASA01221102,

complies with the Machinery Directive and related amendments as well as the national regulations that bring them into force:

Directive

2006/42/EC

Standards

SFS-EN ISO 12100-1 + A1
SFS-EN ISO 12100-2 + A1
SFS-EN 60204-1
SFS-EN 982 + A1
SFS-EN 953 + A1

Ylihärmä,

5 June 2012

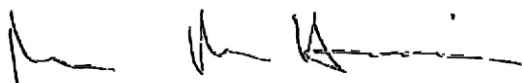

Marko Mäki-Haapoja, Managing Director

DECLARATION OF CONFORMITY FOR THE MACHINE

Manufacturer: **Reikälevy Oy**
Address: Yrittäjätie 22, 62375 Ylihärmä, Finland
Phone: +358 (0)10 425 8000
Fax: +358 (0)6 484 6251
Website: www.reikalevy.fi

We certify exclusively on our own responsibility that the machine placed on the market

 **SAMI** Loading table SLT-W2200, beginning from the serial number LTA01221102,

complies with the Machinery Directive and related amendments as well as the national regulations that bring them into force:

Directive

2006/42/EC

Standards

SFS-EN ISO 12100-1 + A1
SFS-EN ISO 12100-2 + A1
SFS-EN 953 + A1

Ylihärmä,

5 June 2012

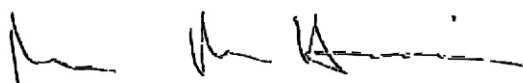

Marko Mäki-Haapoja, Managing Director

SAFETY

This product is intended to be used by a trained professional, familiarized with this Instruction Manual. Never let persons under 18 years old to operate the machine. Never use the machine under influence of alcohol or drugs. **Be always present on the work area**; stop the machine if you intend to go away. Don't let children or animals come close to the machine, or otherwise unsupervised near the machine.

Because the Autosorter machine is designed to operate automatically and its functions may therefore start unexpectedly, **never begin maintenance or repair work while the machine is connected to the power supply!** The logs are conveyed and transferred automatically: don't let tools on the machine and **don't come near the logs as they might move and fall unexpectedly**. For the same reasons, you must **always work alone**. No other person but the user is allowed to be in the work area.

If you see a person or an animal within the danger zone of the machine while the machine is connected to the power supply, e.g. carrying out maintenance work under the machine, on the loading table or in a similar place that could cause a hazard, **PUSH THE EMERGENCY STOP BUTTON!** The hazard zone is 5 m all around the complete installation.

Due to the operational nature of the machine, it is not possible to cover its rotating parts completely without adversely affecting the operation. For this reason, unnecessary presence near the machine must be avoided in order to minimise accident risks. Depending on the layout of the machine, you must ensure that nobody can access the hazard zone unexpectedly. Install a fence or a barrier, and display warning signs about the hazard zone.

When carrying out maintenance work, use caution and make sure that no tools are left in the wrong places before closing the safety covers.

Always use appropriate tools when carrying out maintenance work.

Always place the safety covers back onto the machine before to start it, or before to leave the work area. Disconnect the power supply before to leave the work area.



The environment should be constant, lit and suitable for handling logs. The ground must be adequately cleaned, levelled, firm and clear of any object.

We recommend you to wear suitable personal protection, such as eye guards, noise protection, safety shoes, work gloves.

Never modify the structure of the machine.

Start the machine when you fulfil all those conditions. It is the **operator's responsibility** to ensure the safety requirements at all time during the machine operation.

We strongly advise you to run your own **risk analysis** before to use the product. You should notably study and take notes of the different risks that could be encountered during the machine use, depending on your machine layout and environment: hazard identification (location, type of hazard), harm severity potential, and probability of occurrence. Once all the hazards are assessed, you can take the right risk reduction measures. This will help you to work in maximum safety.

Keep this Instruction Manual available to the machine user at all time.

WARNING LABELS



BEWARE OF CHAIN, used on the loading table and the transfer conveyor to indicate a potential hazard.



BEWARE OF MOVING PART, used to indicate a potential hazard arising from factors such as logs being moved.



BEWARE OF GEARS, used on the transfer conveyor to indicate a potential hazard. Example: feed rollers



BEWARE OF DESCENDING PART, used on Autosorter to indicate a potential hazard. Example: bearers



BEWARE OF MOVING PARTS, used on Autosorter to indicate a potential hazard. Example: log waiting room

TYPE PLATES

SORTER

Type designation of the machine,
 e.g. SAS-W2200

Serial number of the machine.
 ASAxXX XX XX

Working hydraulic pressure

Maximum load on the bearers

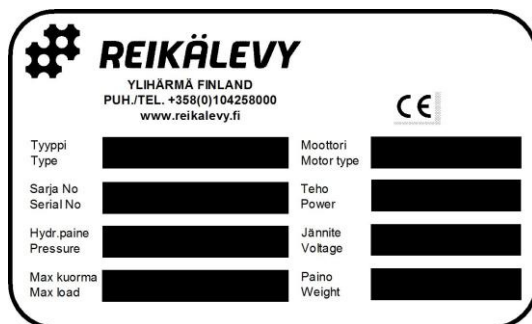

Motor type,
 e.g. 3-phase motor

Size of the hydraulic unit motor

Phase-to-phase voltage

Dry weight of the machine

LOADING TABLE

Type designation of the machine,
 e.g. SLT-W2200

Serial number of the machine
 LTAxxx xx xx

Working hydraulic pressure

Maximum load on the table

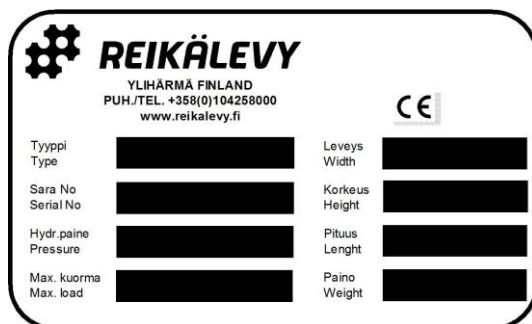

Width of the loading table

Height of the loading table,
 adjustable

Length of the loading table

Dry weight of the machine

GENERAL DESCRIPTION OF THE MACHINE

The SAMI Autosorter (*hereinafter "sorter"*) is designed to sort and transfer logs onto a firewood processor. The machine is the most compatible with the SAMI Autochopper product due to the controls of the two machines communicating via a CAN bus.

However, Autosorter is controlled with a microprocessor of its own and can also serve as an independent log sorter for firewood processors by other manufacturers, but in such a case, full compatibility cannot be achieved.

In terms of overall use, the best utilisation rate can be achieved by connecting the SAMI Loading Table in front of the sorter, whereupon logs can be temporarily stored on the table. From there, the logs are transferred automatically onto the receiving table, controlled by the optical sensors.

Due to the high variability in the shape, thickness and length of logs, the process user must supervise the events and, if necessary, anticipate forthcoming events, e.g. clear log jams, remove branch stumps that affect the mobility of logs etc. This way, the operation will not be halted due to unnecessary disturbances. Particular



caution must be taken for the user's safety, as **the machine operates automatically and unexpectedly**. A remote control delivered with the sorter is used to stop and start the machine.

DESCRIPTION OF THE OPERATION

In short *(more detailed description on pages 12 and 13)*

When Autochopper is in the Automatic, Semi-Auto, Non-Stop or Double Cut mode, the sorter starts up automatically and attempts to transfer logs to the front limit of the Transfer Conveyor, from which they are transferred in accordance with the operation of the Autochopper feed conveyor.

The sorter lifts logs from its receiving table, and in this phase, some of the logs fall off and the remaining logs are lifted. The lifting arms stop and perform a back-and-forth motion in and then out again. The goal of this is for logs that are on top of one another to settle side by side and for excess logs to fall off.

The lifting continues and a measuring process from a pre-set place begins. When the optical sensors detect the outer side of a log, the values are saved to the memory. This is done with both lifting arms.

The lifting arms retraction distance is set as *log diameter / 2 + margin*, whereupon excess logs fall off. After this, the lifting continues all the way up and the lifting arms tip the log into the waiting room through the restraining arms to wait for the Transfer Conveyor availability. If the optical sensors or one sensor have failed to obtain a result during the measuring, the lifting arms are fully retracted and lowered to the bottom position, restarting the lifting routines.

More detailed description of the program cycle

- a) The loading table has transferred logs onto the receiving table of the sorter and the optical sensors have detected the logs, triggering the stop/move back command.
The lifting arms are positioned below the receiving table.
- b) In the pre-sorting phase, the loading table moves back slightly, while the lifting arms rise and collect logs from the receiving table. After rising slightly, the lifting arms perform a fast in/out movement. Excess logs fall off, and the logs remaining on the lifting arms move in a straight position while logs on top of one another are set side by side.
Programmability/adjustability: log detection distance from the sorter frame, movement distance of the loading table, lifting height of the lifting arms, distance and speed of the in/out motion.
- c) The lifting arms rise and stop when the log with the largest diameter meets the sensors (the sensors on both ends must detect the log).
- d) Actual sorting. The lifting arms move inwards, whereupon their distance from the sorter frame is slightly greater than half of the diameter measuring result. Only one log rests against the sorter frame. All other logs fall off the lifting arms as the one selected log is placed against the sorter frame.
Programmability/adjustability: length of the inwards movement of the lifting arms
- e) A new measuring is performed. Because the selected log was already placed against the sorter frame, it is the only log remaining on the lifting arms. The lifting arms move back out, ensuring that the log stays on the bearers as the lifting begins and the log is tipped into the waiting room.
- f) The lifting arms reach the highest point of the sorter and tip the log onto the restraining arms on the back of the lifting arms.
- g) The lifting arms move inwards and the log is lowered by the lifting arms towards the waiting room.
- h) The lifting arms and restraining arms move down, releasing the log to fall into the waiting room.
- i) The log is placed in the waiting room to wait for the transfer conveyor to be cleared of the previous log.
The loading table transfers new logs onto the receiving table of the sorter, if there are no logs remaining from the previous round.
- j) The log is dropped from the waiting room onto the transfer conveyor, from which it is transferred to the firewood processor. At first, the log is transferred at full speed, and when it reaches the sensor in the front of the feed chute, the speed and forward commands of the chute are transferred to cooperate with the Autochopper feed table. A new cycle begins at the same time.
Now the lifting arms have a smaller log against the sorter frame and a larger log next to it. The measuring is carried out according to the larger log.
- k) The lifting arms move inwards, whereupon their distance from the sorter frame is slightly greater than half of the diameter of the larger log. Because the log is not placed against the sorter frame, it falls off.
Programmability/adjustability: the lifting arms' distance from the frame in relation to the diameter of the log. As the sensors are now unoccupied, the lifting continues higher and another measuring is performed, based on which the lifting arms move inwards. The log stays on the lifting arms because it is placed against the sorter frame.
- l) The lifting arms move outwards, lift the log up and tip it onto the retaining arms and then into the waiting area.

The cycle continues.

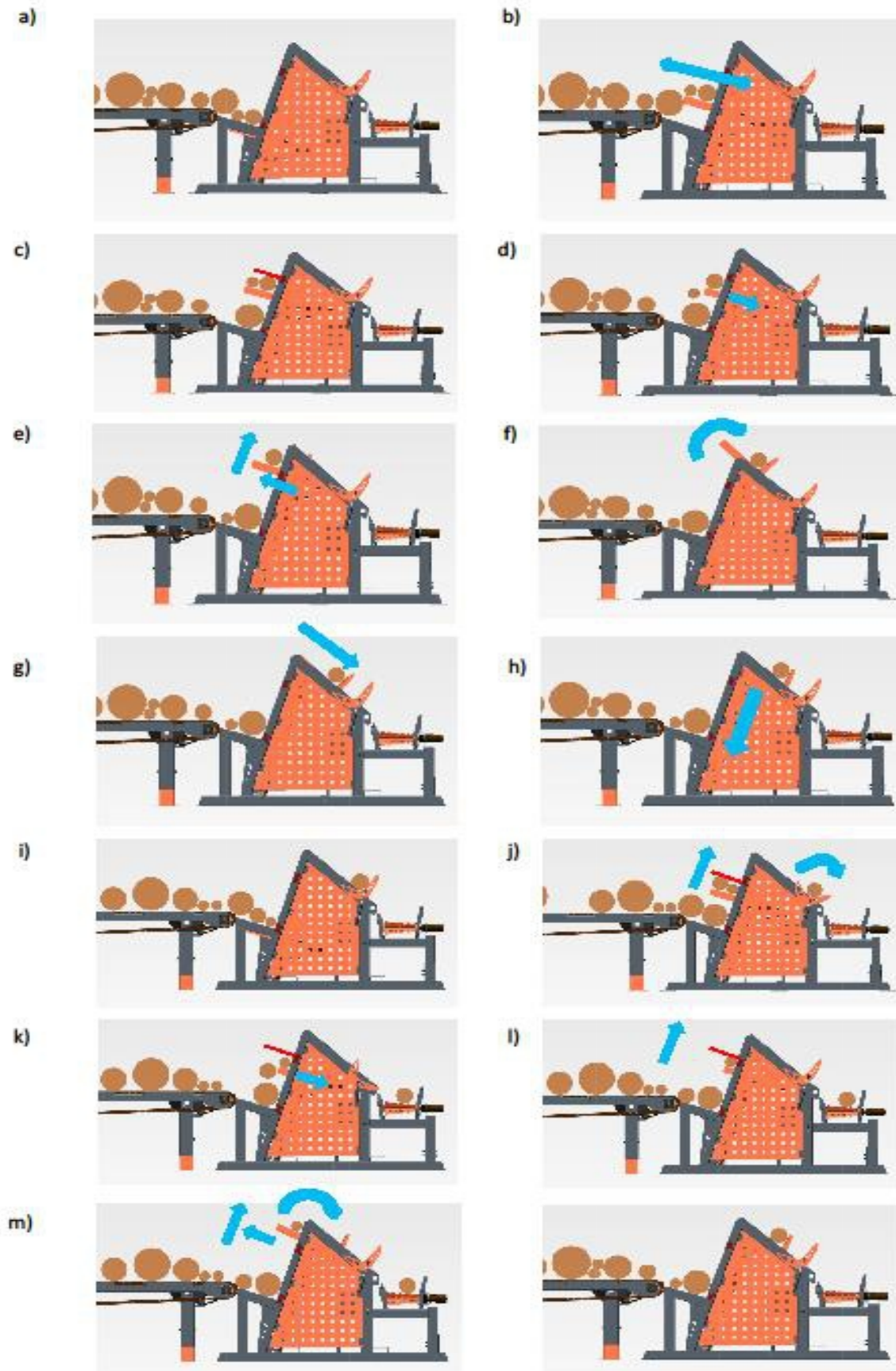

INSTALLATION

SORTER

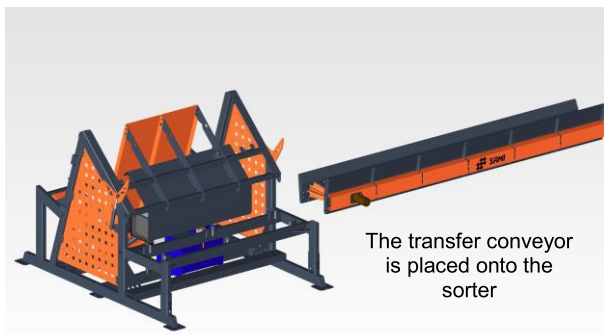
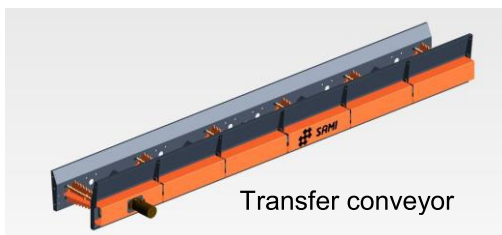

SAMI Autosorter technical data

Weight	1100 kg
Width w/o Transfer Conveyor	2340 mm
Width with Transfer Conveyor	4015 mm
Length	2940 mm
Height	1910 mm
Max. load	1200 kg
Hydraulic operating pressure	170 bar
Electric motor	5.5 kW
Switching voltage Europe	400 V / 50 Hz
Switching voltage USA	480 V / 60 Hz

There are no height adjustments in the legs of the sorter, so the installation area must be levelled first. Lift the machine with a device such as a forklift or a loader with slings. Due to the weight of the machine, use caution and care and avoid quick movements when moving the machine.

DO NOT go or let anyone else go under the machine while it is being moved. Secure your work area!



The transfer conveyor is usually delivered unassembled. Install the conveyor by lifting it onto its designated platform.

The conveyor can be adjusted laterally, and when the desired position is found, the conveyor is fastened into place with bolts.

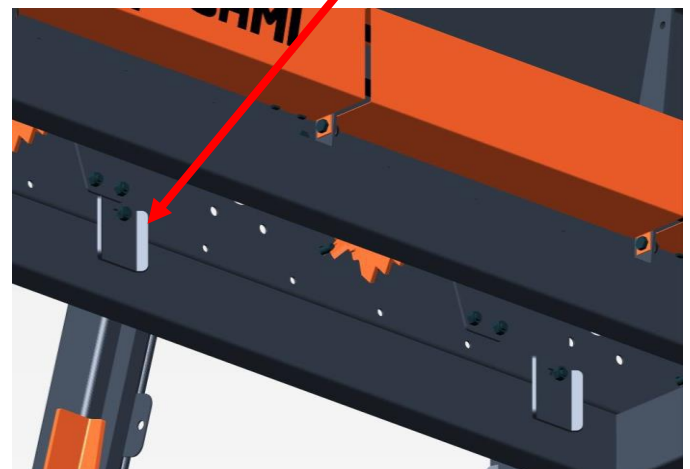

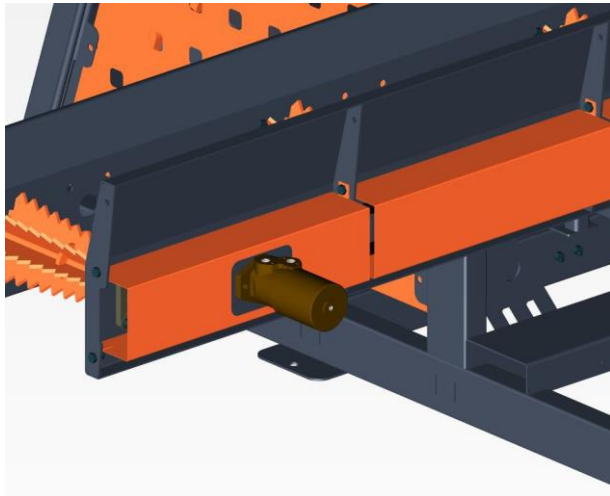

The hoses of the hydraulic motor are connected and tightened (e.g for the SAMI Autosorter package: hydraulic hoses to Loading Table and Transfer Conveyor).

The sorter is now installed.

Make sure that no cable or hose was damaged during the transport or installation.

If everything is OK, the power plug (16A) can be connected to the grid and test runs performed.

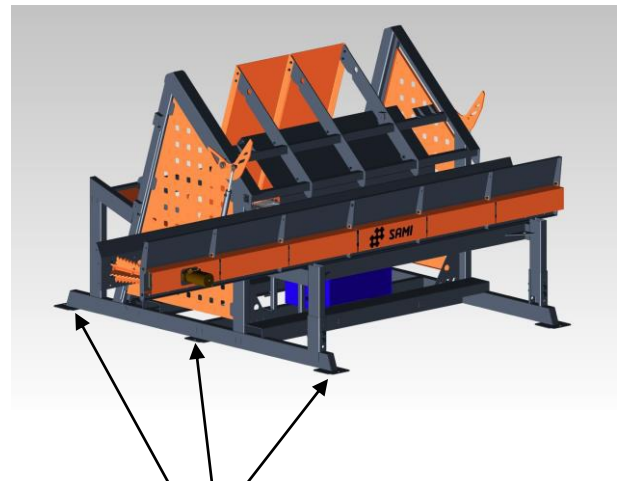
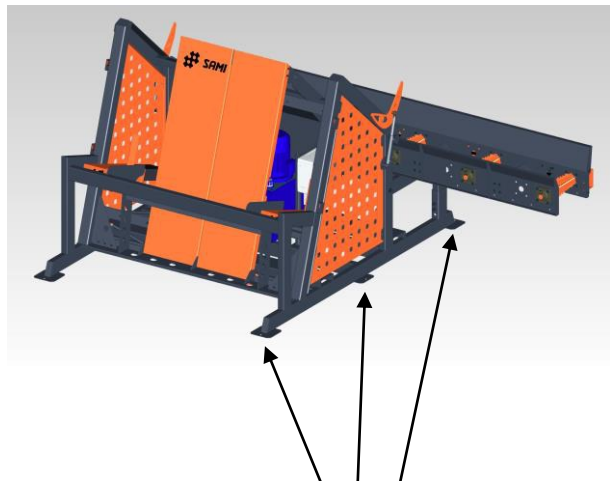

We advise that the sorter is anchored to the ground in six (6) spots. This will prevent the machine from moving during its operation.
For the least, fasten the loading table to the sorter to prevent heavy wood to push one or the other equipment during the conveying.
Unanchored equipment can result in hazardous situations.



Connecting to SAMI Autochopper

If the sorter is connected to the firewood processor SAMI Autochopper, the control computers of the machines must be connected. This is done by connecting an RS232 cable to the CAN bus of the machines. Once connected, the sorter can be started and its movements can be controlled from the Autochopper panel. This RS232 cable is located into the Autochopper on every delivery.

Photosensor locations and models

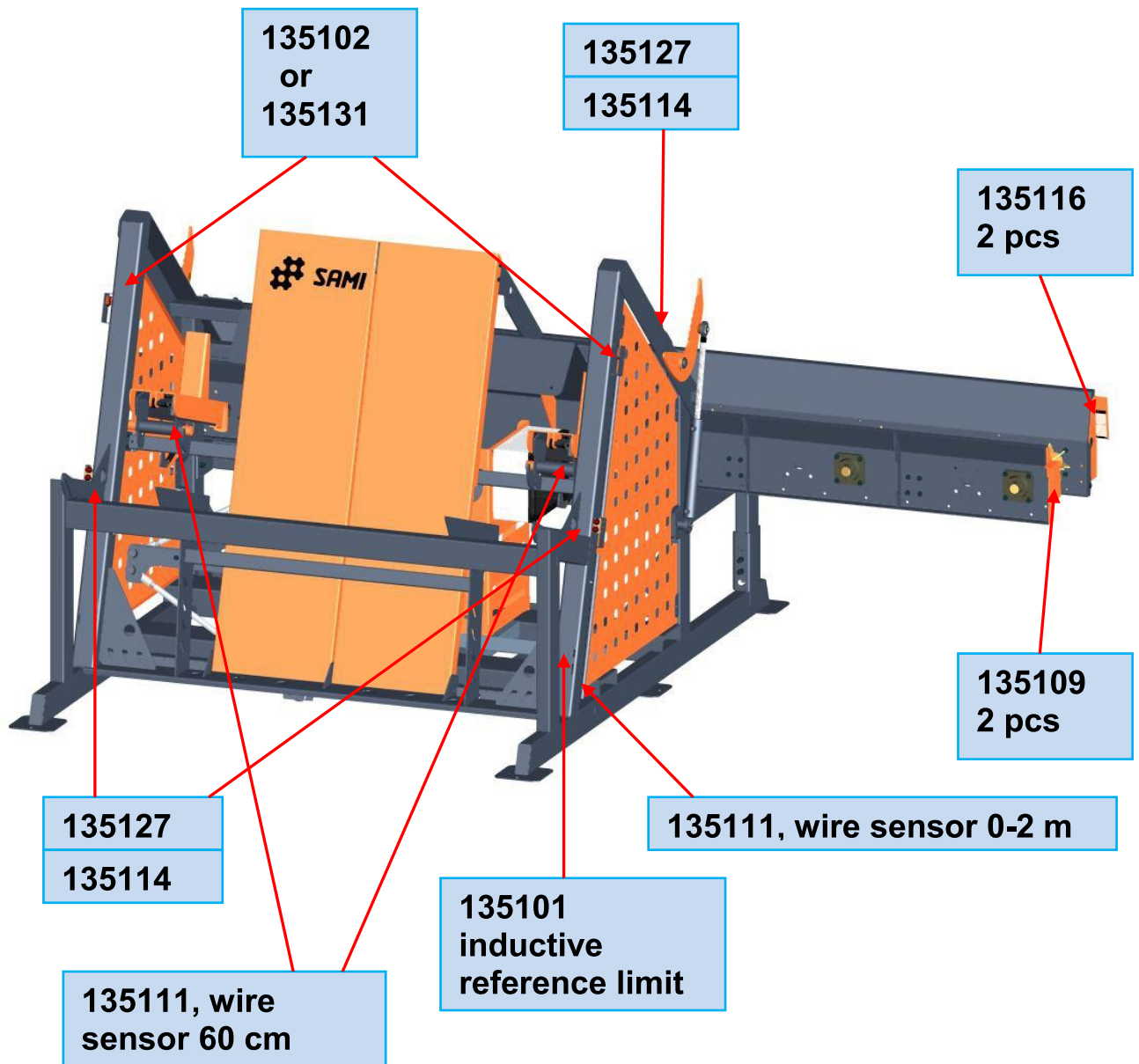

SORTER MAIN PARTS

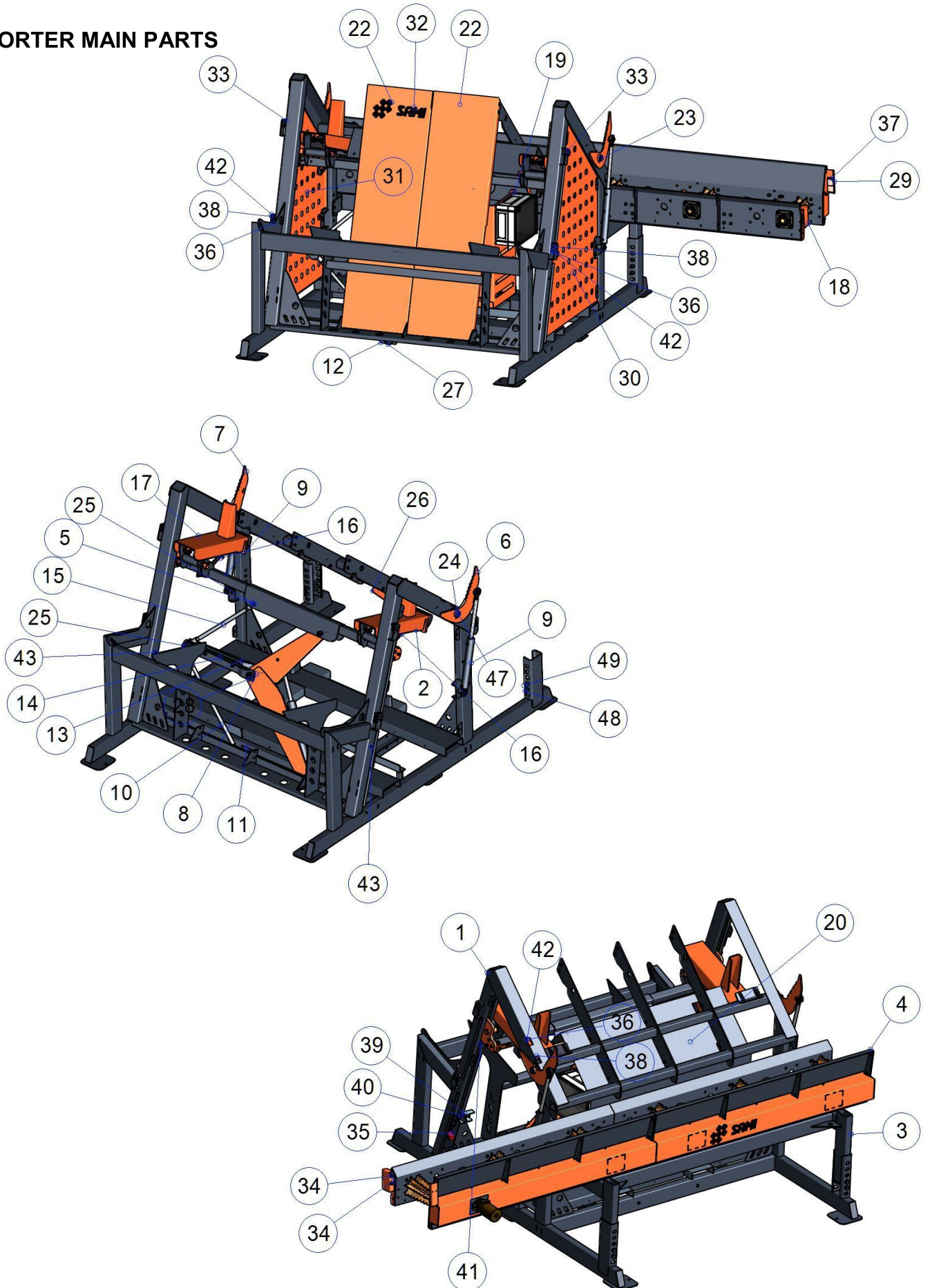

Number	Reference	Description	Amount
1	41810	Sorter frame	1
2	41845	Lifting arm Left	1
3	41854	Feeding chute frame	1
4	44124	Feeding chute 4 m, low edge	1
5	41885	Lifting bar	1
6	41897	Stopper Right	1
7	41901	Stopper Left	1
8	41889	Sorter lifter	1
9	41996	Stopper cylinder	2
10	41935	Lower draw bar	1
11	41940	Trapeze lower support Left	1
12	41941	Trapeze lower support Right	1
13	41943	Trapeze intermediate support Left	1
14	41945	Trapeze intermediate support Right	1
15	41950	Upper draw bar	1
16	T4808K	Gas spring 188+150 850N, assembled	2
17	41844	Lifting arm Right	1
18	41926	Sensor support, for 2 sensors M18	1
19	42125	Electric center and its support	1
20	41958	Upper cover plate	1
21	16211	Lubrication nipple M6	2
22	41831	Protective mask	2
23	41850	Bearing sleeve d40xD44...30 Brass	2
24	41942	Intermediate sleeve L44 trapeze	2
25	41946	Kingpin D25 L104 h9	3
26	41959	Upper protective bracket	3
27	41951	Kingpin D25 L123 h9	1
28	41952	Locking plate D50 d11 S3	2
29	42703	Test plate for the reflector	1
30	41960	Protective wall Left	1
31	41961	Protective wall Right	1
32	TARR10006	SAMI sticker big 15 x 47.5 cm	1
33	135102	Light sensor HTR 25	2
34	135109	GRL18SG-F2337	2
35	135111	Wire sensor 2 m (yoyo sensor)	1
36	135114	Photocell PA18CAD	3
37	135116	Reflector, rectangular	2
38	135127	GRTE 18S-P2347	3
39	41805	Protective plate for the sensor	1
40	41853	d12 sensor angle plate	1
41	41997	Yoyo lifting upper plate	1
42	41999	Sensor holder	4
43	Rasvanip_M8_suora		4
44	TBN40047M6x1	Greasing nipple	3
45	24017-M12x90	Hex screw, full thread	2
46	471-15x1	Retaining ring for the shaft	3
47	471-40x1.75	Retaining ring for the shaft	2
48	-	DIN_EN_24014-M20x160	3
49	-	DIN_EN_24017-M20x160	1
50	-	DIN_EN_24014-M12x70	2
51	-	DIN_EN_24014-M20x90	2
52	24017-M10x20	Hex screw, full thread	2
53	-	DIN_EN_ISO_10511-M12	2
54	-	DIN_EN_24017-M10x25	12
55	-	DIN_EN_ISO_10511-M10	13
56	-	DIN_EN_24032-M3	2
57	-	DIN_EN_ISO_1207-M3x20	2
58	-	DIN_EN_24014-M10x80	2
59	-	DIN_EN_28675-AM16	2
60	125-A6.4	Washer, flat	2
61	9021-10	Washer	4
62	-	DIN_EN_24017-M10x25	4
63	24017-M6x16	Hex screw, full thread	2

SORTER DIMENSIONS

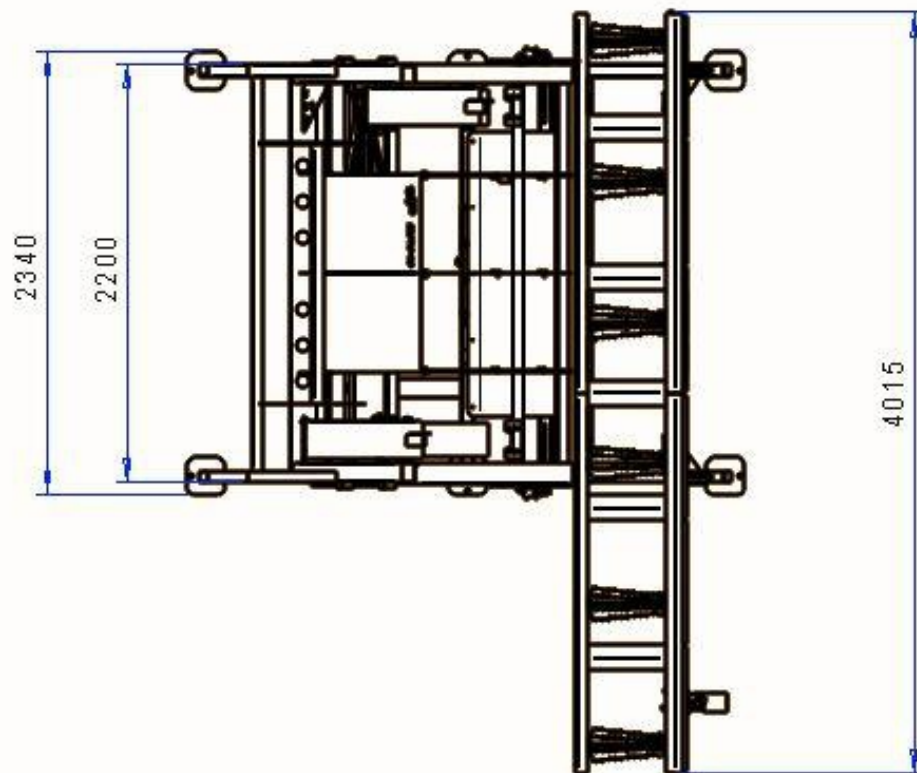
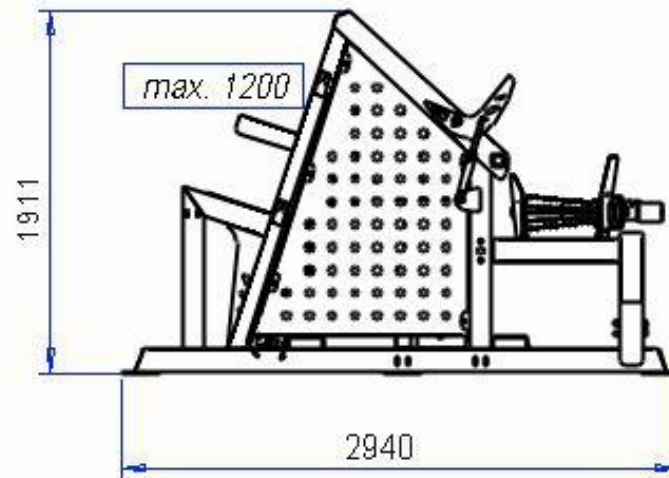

LOADING TABLE

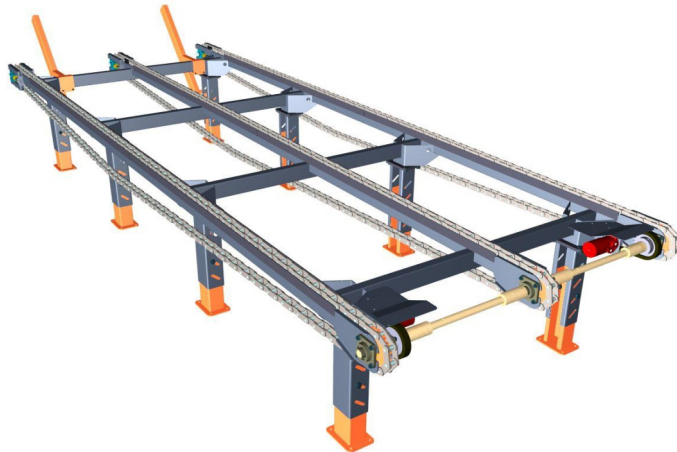

The loading table is usually assembled at the factory. The legs can also be delivered dismounted and therefore need to be installed on site. The hydraulic motor hoses must be connected to the loading table before start.

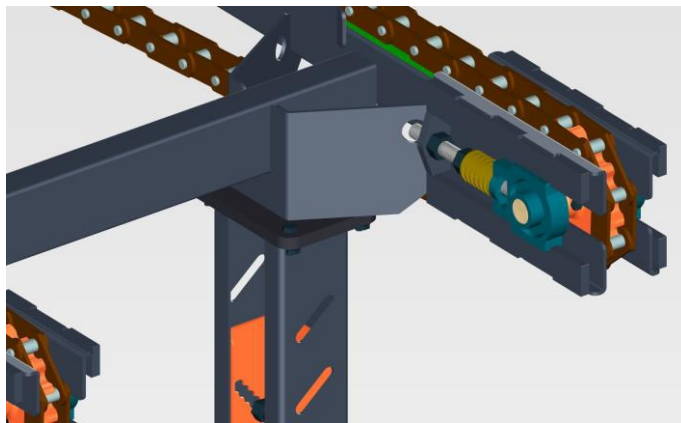

The legs are installed onto their designated plates and fastened with screws and bolts. When attaching the legs, the loading table needs to be lifted and supported by an appropriate machine during the installation. Avoid any hazardous operation and ask for professional service if you don't have the skills or the right equipment.

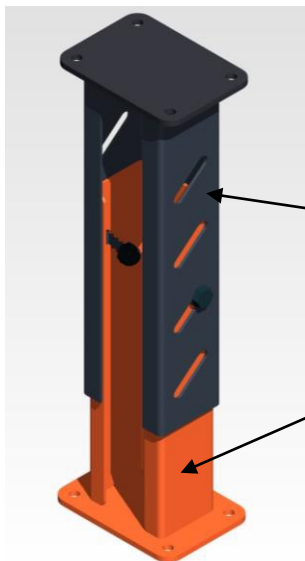

The legs feature a height adjustment that can be used to level the table in both the longitudinal and lateral directions.

The upper part of the leg features 4 angled slots for a rough adjustment.

The lower part features 1 slot in a different angle, which can be used to make a final adjustment with approximately 1 cm accuracy.

LOADING TABLE 6.5 m [43100] PARTS

SAMI Loading Table 6.5 m technical data

Weight	1070 kg
Width	2300 mm
Height	886-1285 mm
Length	6500 mm
Max. load	18000 kg
Hydraulic operating pressure	170 bar

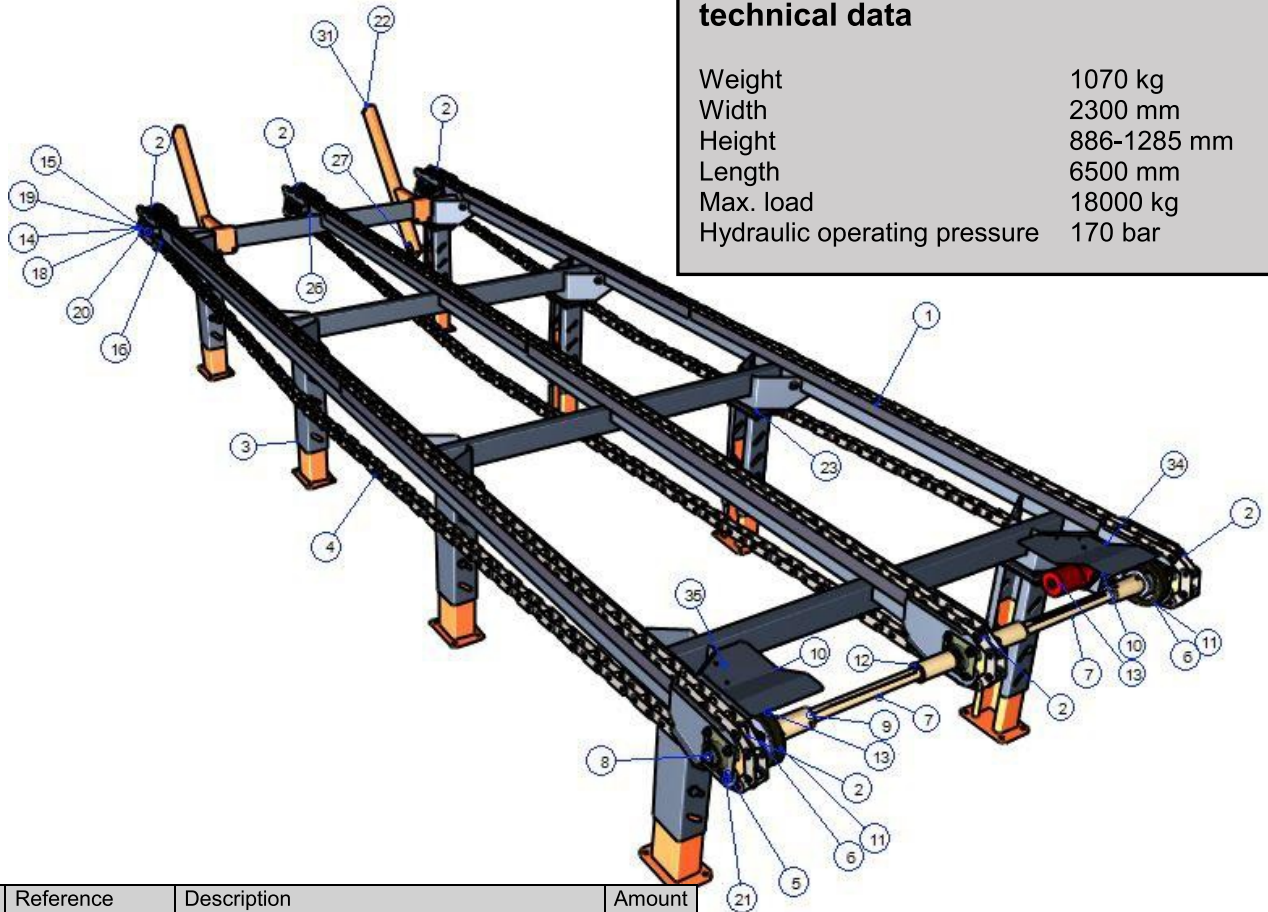

Number	Reference	Description	Amount
1	43110	Loading table frame	1
2	43135	Drive gear	6
3	43145	Adjustment foot	8
4	43121	Conveying chain M112-A-80	3
5	41907	UCF208	6
6	41916	Chain wheel Z21/d40	2
7	43104	Drive shaft D40L610	2
8	43105	Transmission shaft d40...360	3
9	43106	Coupling sleeve d40L160	4
10	43115	Chain wheel Z10/d25	2
11	44108	Transmission chain	2
12	43144	Gusset 12x8...160	4
13	13130	Hydraulic motor CPM500CD	2
14	43103	Tool spring 50/25...76	6
15	43108	UCT208	6
16	43127	Spring tension adjustment screw M24...250	6
18	43154	Axle d40...210 in locking recess	3
21		DIN_6923-M12	53
22	41990	Rear bumper	2
23	24017-M12x40	Hex screw, full thread	31
24	24017-M12x40	T933M1240	1
25		DIN_EN_24032-M16	2
26		T934M24	12
27	41994	Rear bumper locking pin	2
28		SFS_2636-A-12x8x80	3
29	24017-M10x20	Hex screw, full thread	6
31	IR601202-3S	Inner cap, black	2
32		DIN_EN_24014-M10x90	6
33		DIN_EN_ISO_10511-M10	7
34	44113	Debris protection plate Right	1
35	44114	Debris protection plate Left	1

LOADING TABLE 3.5 m [44100] PARTS

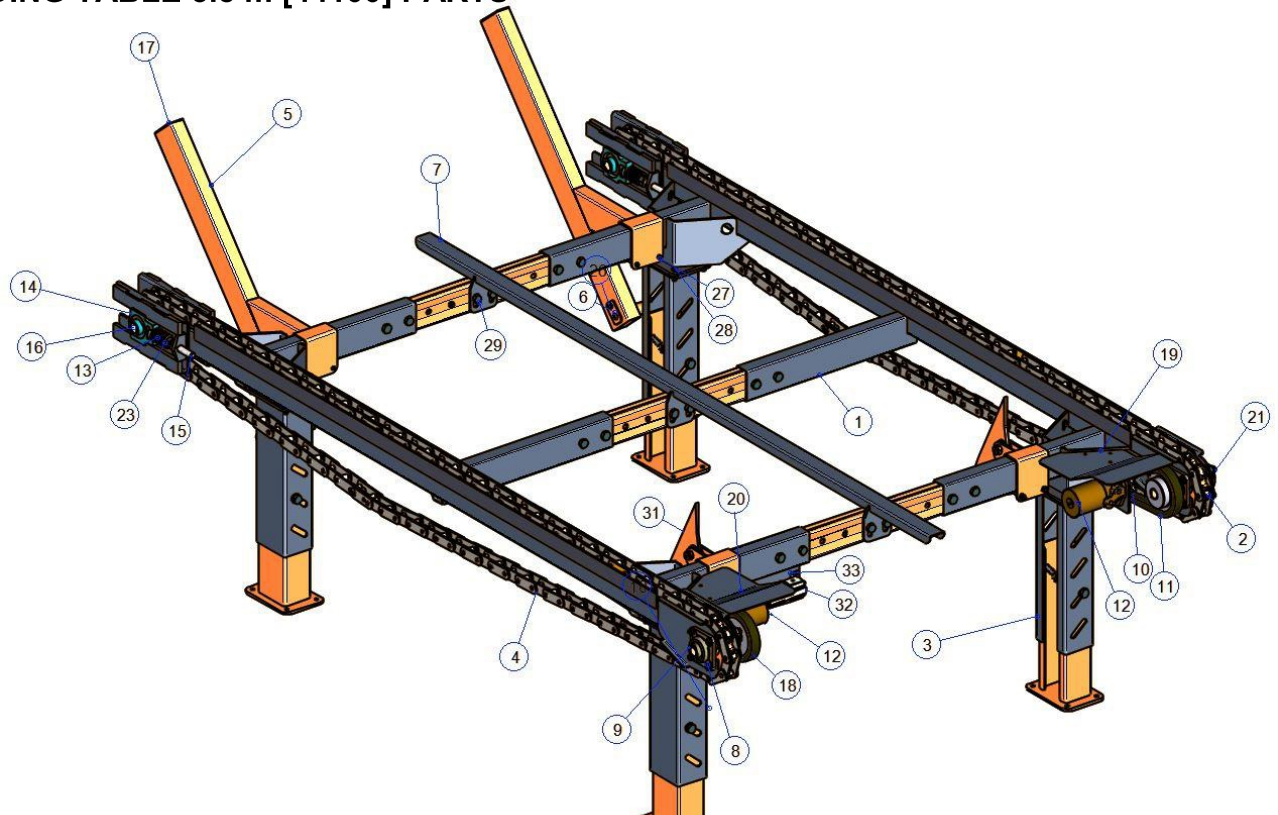

Number	Reference	English	Amount
1	44110	Loading table frame, assembled	1
2	43135	Drive gear	4
3	43145	Adjustment foot	4
4	44105	Conveying chain M112-A-80	2
5	41990	Rear bumper	2
6	41994	Rear bumper locking pin	2
7	44115	Free central beam	1
8	41907	UCF208	4
9	44104	Transmission shaft d40...252	2
10	43115	Chain wheel Z10/d25	2
11	44108	Transmission chain	2
12	13129	Hydraulic motor CPM400CD	2
13	43103	Tool spring 50/25...76	4
14	43108	UCT208	4
15	43127	Spring tension adjustment screw M24...250	4
16	43154	Axle d40...210 in locking recess	2
17	IR601202-3S	Inner cap, black	2
18	41916	Chain wheel Z21/d40	2
19	44113	Debris protection plate Right	1
20	44114	Debris protection plate Left	1
21		DIN_6923-M12	32
22		DIN_EN_24032-M16	2
23		T934M24	8
24		SFS_2636-A-12x8x80	2
25	24017-M10x20	Hex screw, full thread	4
26		DIN_EN_24014-M12x90	6
27		DIN_EN_ISO_10511	4
28	24017-M12x40	Hex screw, full thread	16
29		DIN_EN_24017-M20x90	6
30		DIN_EN_ISO_10511-M20	6
31	44133	Reverse stopper	2
32	135510	Distribution motor 1-->2	1
33	135511	2 way distribution motor plate	1

SAMI Loading Table 3.5 m technical data

Weight	600 kg
Width	1600-2200 mm
Height	886-1285 mm
Length	3500 mm
Max. load	18000 kg
Hydr. operating pressure	170 bar

LOADING TABLE 6.5 m [43100] DIMENSIONS

Note: The Loading Table 3.5 m [44100] differs by its length (3.5 m) and its width (adjustable, between 1.6 and 2.2 m).

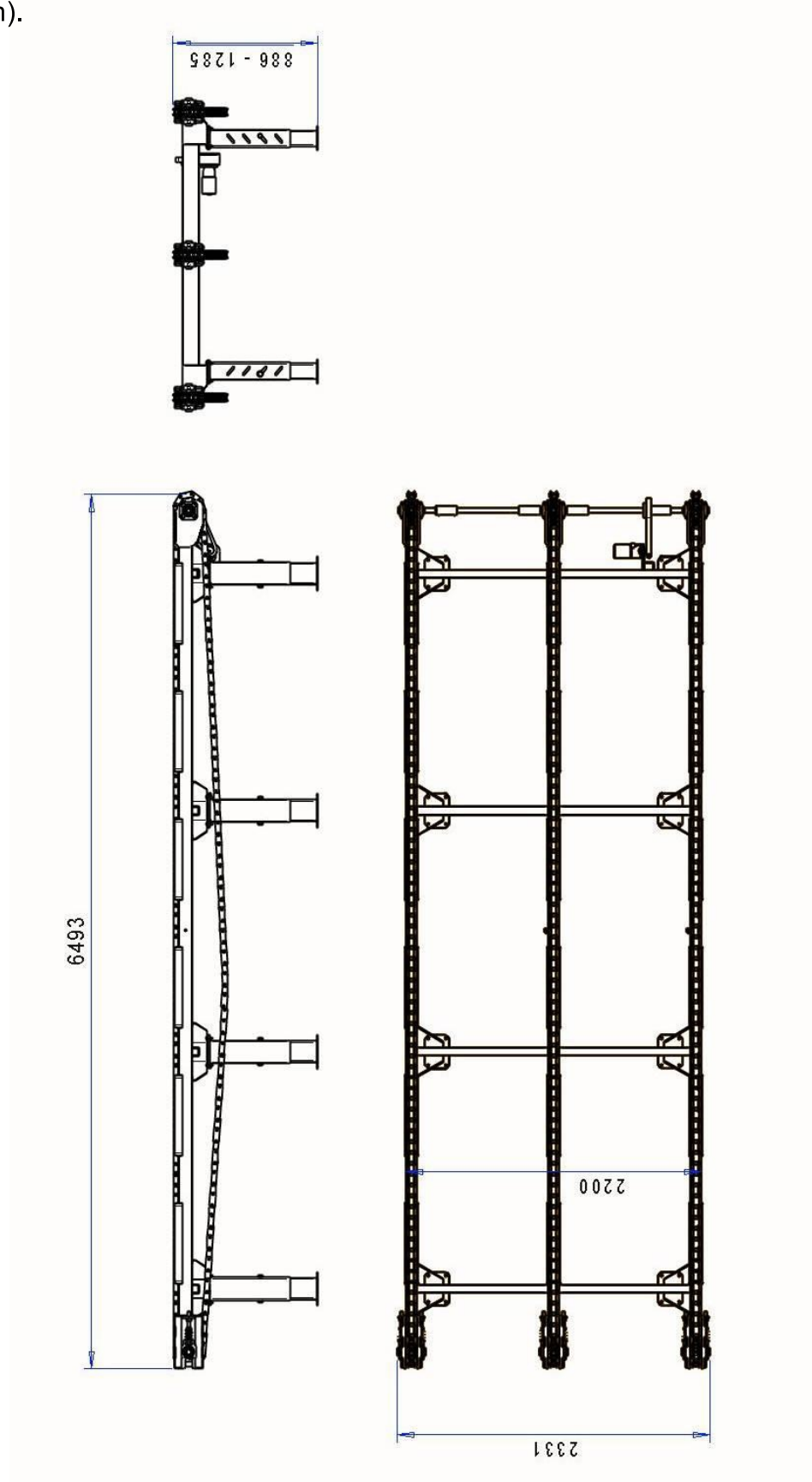

COMBINING THE SORTER AND THE LOADING TABLE

Install the loading table as close to the receiving table of the sorter as possible. However, the conveyor chain must not touch the sorter.

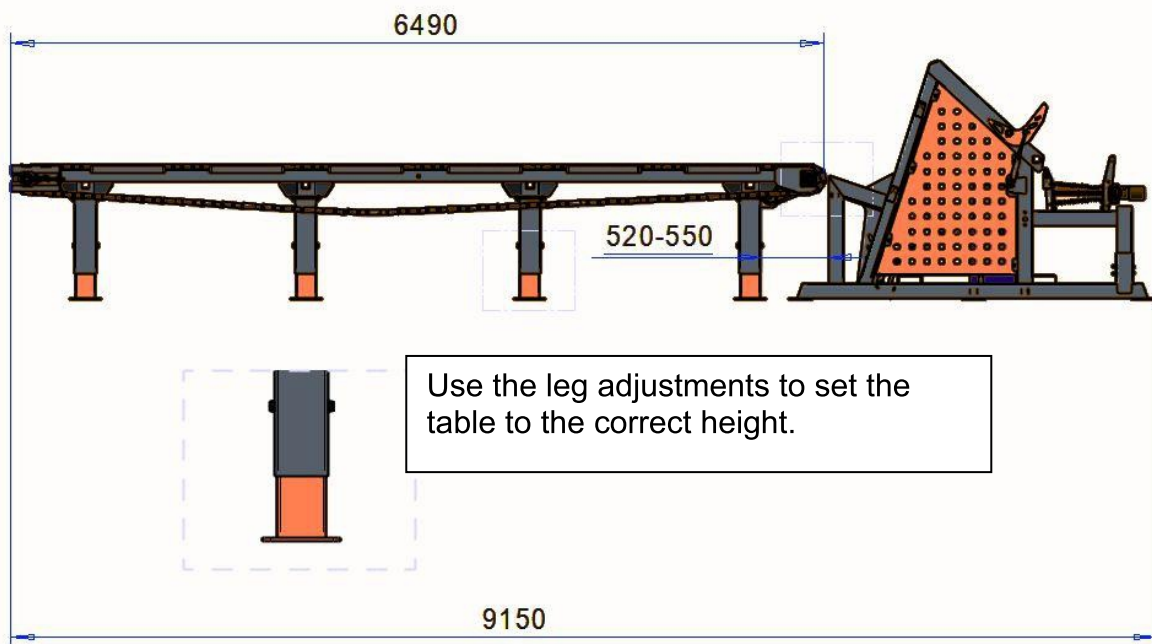
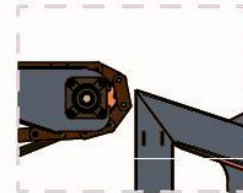

USER INTERFACE

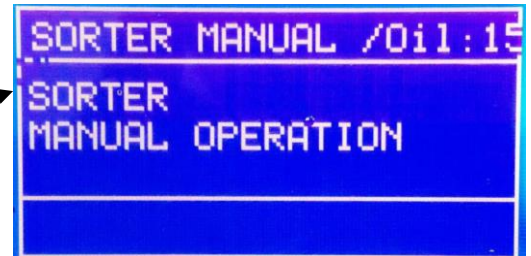

On Autochopper, select the menu Sorter Manual shown in the image, after which the Autosorter unit and controls can be started with the **green Start** button.

The **red Stop** button stops the machines.

Function 1: Pushing the joystick up raises the lifting arms.

Function 2: **Pressing the side button** and pushing the joystick up moves the loading table feed **FORWARD**.

Pressing the top button and pushing the joystick up turns the waiting room **stoppers DOWN**.

Function 1: Pushing the joystick left extends the lifting arms.

Function 2: **Pressing the side button** and pushing the joystick left rotates the table rollers **BACKWARDS**.



Function 1: Pushing the joystick right retracts the bearers.

Function 2: **Pressing the side button** and pushing the joystick right rotates the table rollers **FORWARD**.

Function 1: Pushing the joystick down lowers the lifting arms.

Function 2: **Pressing the side button** and pushing the joystick down moves the loading table feed **BACKWARDS**.

Pressing the top button and pushing the joystick down raises the waiting room **stoppers UP**.

MANUAL USE DURING THE AUTOMATIC PROCESS

Beginning from the software version srt_2.4.0 (2016), the sorter can be used manually during the automatic cut process. The display software should also be updated to version chp_dsp_2.6.0 or newer, whereupon the manual mode can also be shown on the display.

Operation:

This mode is available when Autochopper is in any of the automatic modes (Automatic, Non-Stop or Double Cut modes).

In these modes, all is running automatically, including the sorter. The automatic operation of the sorter can be aborted, but Autochopper will continue to operate in the mode that was previously selected. Now the sorter can be controlled with the Autochopper joystick, as described in the previous section. The sorter can be returned to the automatic mode by pressing the START button again for 1 second. If the operation has been stopped with the STOP button, the sorter will also enter the automatic mode with the next start.

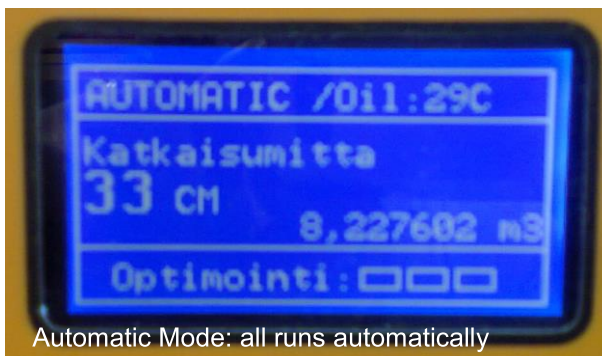

Automatic Mode: all runs automatically

Autochopper started in the automatic mode, whereupon the sorter also enters the automatic mode.



Push the joystick up for approximately 5 seconds until the text SORTER is displayed. Now the sorter can be controlled with the joystick.

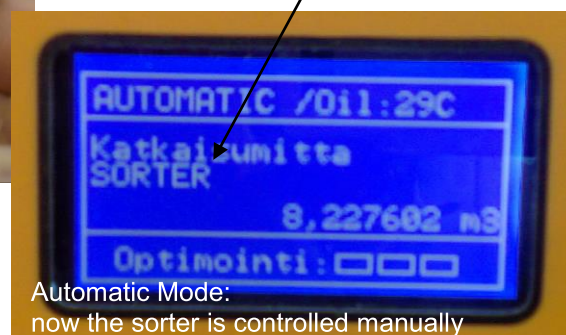

Automatic Mode:
now the sorter is controlled manually



Press the START button again for approximately 1 second and the sorter returns to the automatic mode.

I/O states

On I/O States mode, screen provides information of the status and operation of Autochopper measuring sensors.

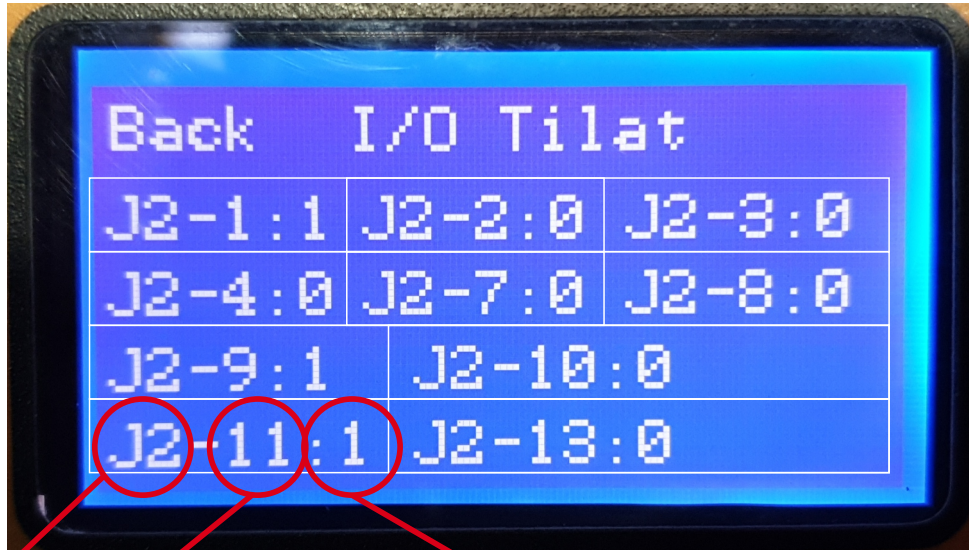

Not relevant information

SENSOR NUMBER	DESCRIPTION	SENSOR STATE
		1 = Sensor is active / 0 = Sensor is not active
1	Emergency stop button position sensor	1= Power is ON
2	Log lifter limiting sensor (optional)	0= log lifter is NOT in up pos.
3	Log position sensor (3pc light sensors)	0= NO logs between sensors
4	Log position sensor (3pc light sensors)	0= NO logs between sensors
5	Not in use	
6	Not in use	
7	Log splitting piston IN position sensor	1= piston is fully in IN pos.
8	Log splitting piston OUT position sensor	1= piston is fully in OUT pos.
	<i>Notice! PISTON is NOT FULLY on neither position (In or out) then BOTH values of sensor state is 0.</i>	
9	Saw blade UP position sensor	1= blade is fully in UP pos.
10	Saw blade DOWN position sensor	1= blade is fully in DOWN pos.
	<i>Notice! If SAW BLADE is NOT FULLY on neither position (In or out) then BOTH values of sensor state is 0.</i>	
11	Sawn log pusher position sensor	1= log pusher is fully in IN pos.
12	Not in use	
13	Security switch position sensors (2pc) - Splitting blade (tarpaulin) cover - Main steel cover	1= Both covers are securely closed

HANDLING OIL



- When handling oil or grease, always wear appropriate protective clothing and oil-resistant gloves.
- Avoid skin contact with oil and grease. They may damage your skin.
- Never use oil or lubricating grease to clean your skin! These substances may contain small metal particles that cause cuts, which are further aggravated by the oil.
- Follow the lubricant manufacturers' handling instructions and safety regulations.
- Synthetic oils are often corrosive and cause severe skin irritation.

WASTE OIL

- Waste oil must be collected and taken to be properly disposed of in accordance with national regulations.

ACCIDENTS

- If any oil ends up in the ground, it must be stopped from spreading and collected with absorbent material.
- If oil or lubricating grease causes skin damage, seek medical attention immediately.

DECOMMISSIONING THE PRODUCT

- Decommissioning the product in its entirety is the responsibility of the end user or the person or business whose property the product is upon decommissioning.
- There are national laws, instructions and regulations that must be complied with in all user countries regarding the decommissioning of the product and the processing of various types of waste that are created.
- The product contains non-biodegradable materials, and thus the machine must be dismantled and the different materials disposed of in accordance with national regulations:
 - Iron and other metals are recycled through machine dismantling companies for reuse.
 - Waste oil, plastics and rubber parts are processed as hazardous waste and disposed of either by recycling or taking them appropriately to a landfill site or otherwise disposed of in accordance with national regulations.
- If necessary, contact the environmental authorities for more information regarding the dismantling and the processing of waste.

TROUBLESHOOTING

The table below lists some of the most typical deviations and their solutions.

Disturbance	Possible cause
The motor of the unit does not start when the START button is pushed.	<ul style="list-style-type: none"> - The power plug is disconnected from the grid. - The CAN bus cable is detached or the connectors have poor contact. - There is an error in the soft starter. - A fuse has blown. - The controller card has been broken by a thunderstorm, for example.
The loading table motor does not rotate.	<ul style="list-style-type: none"> - Broken hose. - There are already logs in front of the optical sensors (automatic mode). - The optical sensors give erroneous information (automatic mode). - At least one block valve control cable is detached. - The hydraulic motor is broken. - The hydraulic unit is not running.
The lifting arms do not work or are stuck in a maximum travel position.	<ul style="list-style-type: none"> - Broken hose. - At least one block valve cable is detached. - The adjustment valve is broken. - The placement sensor of the lifting arms provides erroneous information (coil sensor in the arms). - The lifting arms cannot find the reference limit upon start-up (inductive sensor low). - The CAN bus cable is detached or the connectors have poor contact. - The hydraulic cylinder is damaged. - The hydraulic unit is not running.
The lifting arms do not move in/out.	<ul style="list-style-type: none"> - Broken hose. - At least one block valve cable is detached. - The placement sensor of the lifting arms provides erroneous information (coil sensor, inside the bearer). - The CAN bus cable is detached or the connectors have poor contact. - The hydraulic cylinder is damaged. - The hydraulic unit is not running.

<p>The roller table does not rotate.</p>	<ul style="list-style-type: none"> - Broken hose. - There is a log in front of the optical sensor (automatic mode). - The optical sensor gives erroneous information (automatic mode). - At least one block valve control cable is detached. - The hydraulic motor is broken. - The hydraulic unit is not running.
<p>The waiting room stoppers do not turn.</p>	<ul style="list-style-type: none"> - Broken hose. - At least one block valve control cable is detached. - The hydraulic cylinder is broken. - The hydraulic unit is not running. - The stoppers are stuck and the turning time has ended (automatic mode).
<p>After start up, the bearers attempt to keep moving down even though the bottom position has been reached.</p>	<ul style="list-style-type: none"> - The reference limit is broken or does not detect metal when the bearers are in the bottom position.

MAINTENANCE

Sorter greasing locations

 First, **disconnect the power supply** from the machine, before any maintenance operation!

In normal daily use, the machine should be greased at least once a month.
If necessary, grease more often, e.g. once a week.

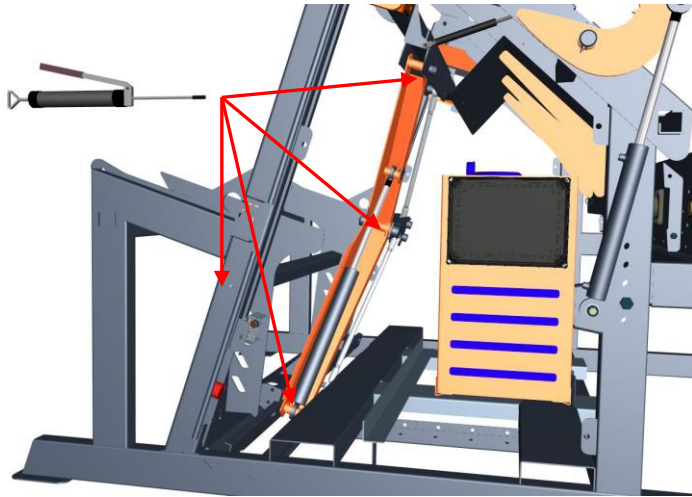

Lifting arm joints and
cylinder ears.

Also, grease the lifting
columns when the sliders
are down.

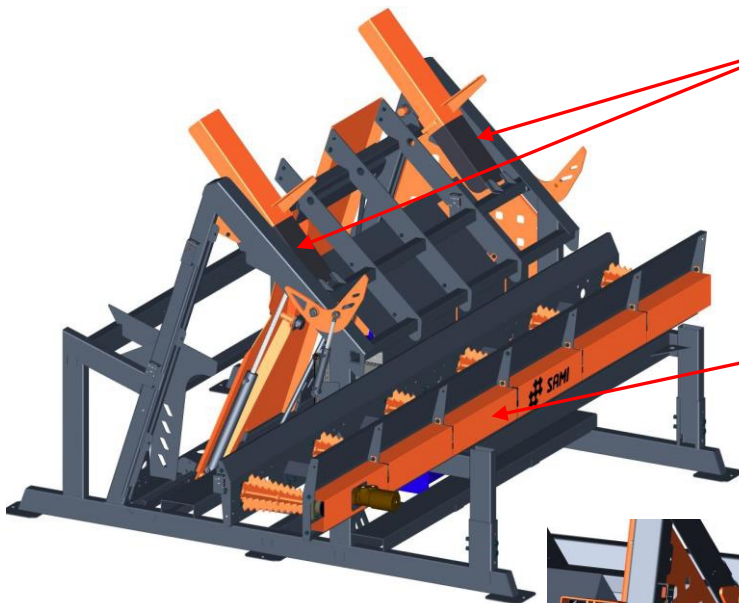

At times, apply
petroleum jelly to the
sliding parts of the lifting
arms to decrease friction.

The roller table chains
are greased
approximately once a
month.

The covers must be
removed for the
greasing.

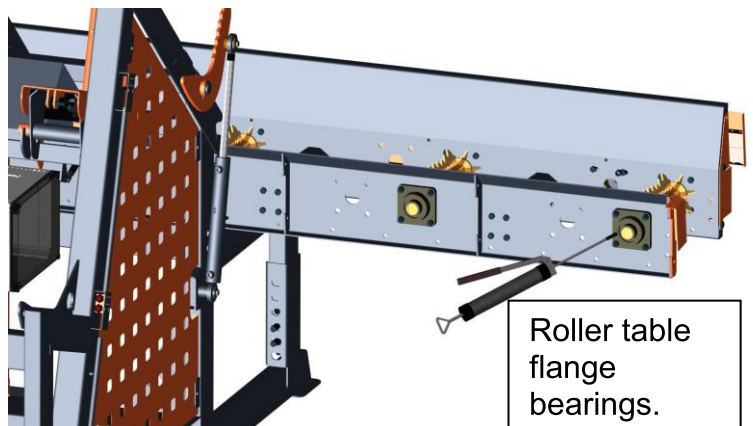

Roller table
flange
bearings.

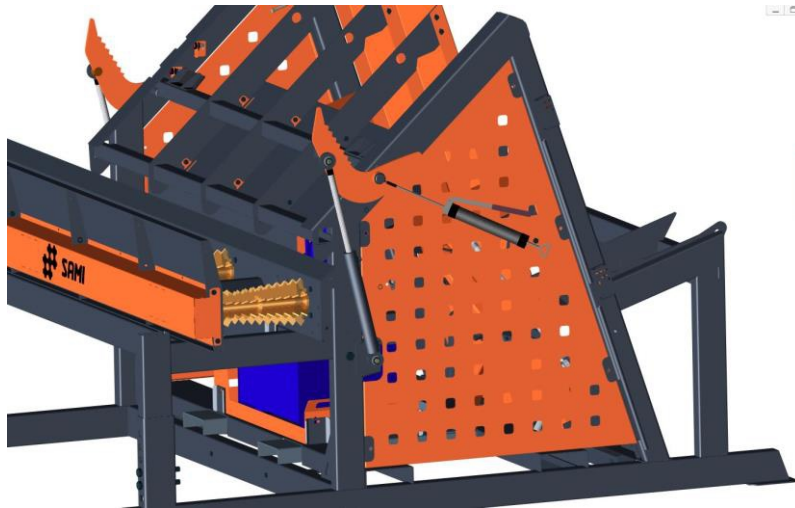

Waiting room
stopper cylinder
ears and joint.

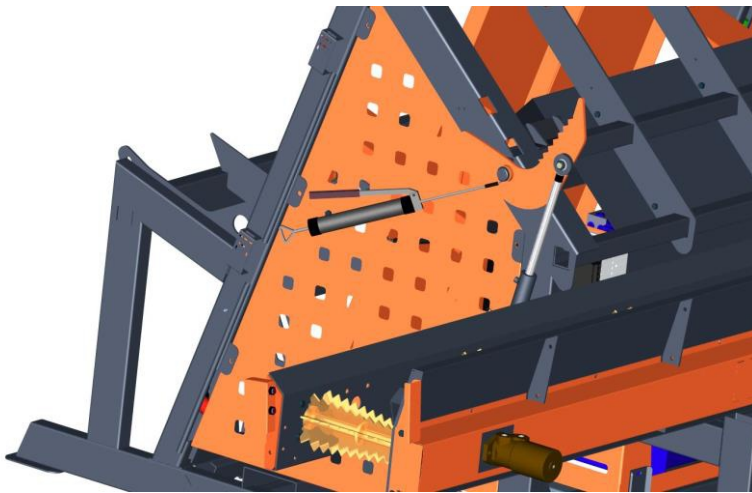

Lifting arms joints.

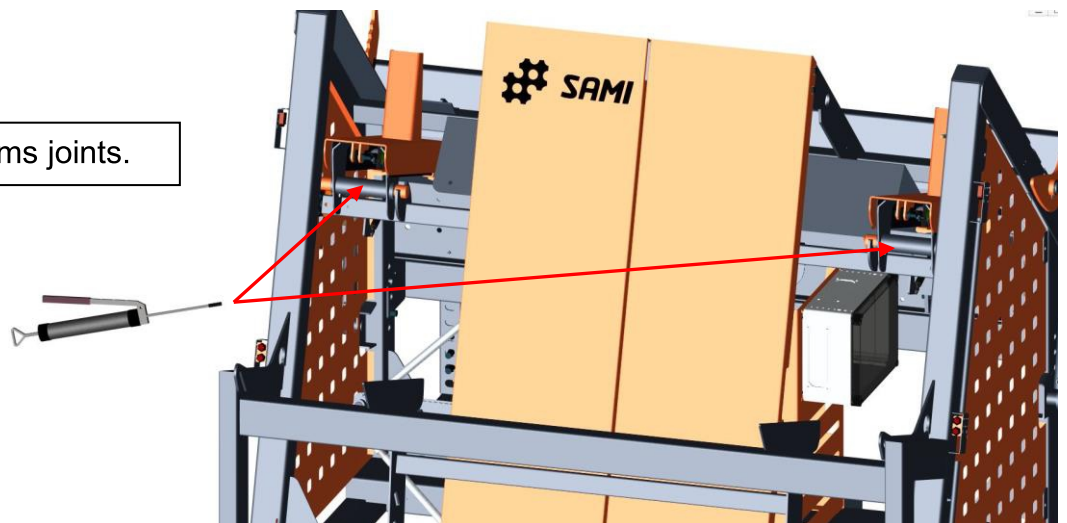

Loading table 43100 greasing locations

In normal daily use, the machine should be greased at least once a month.

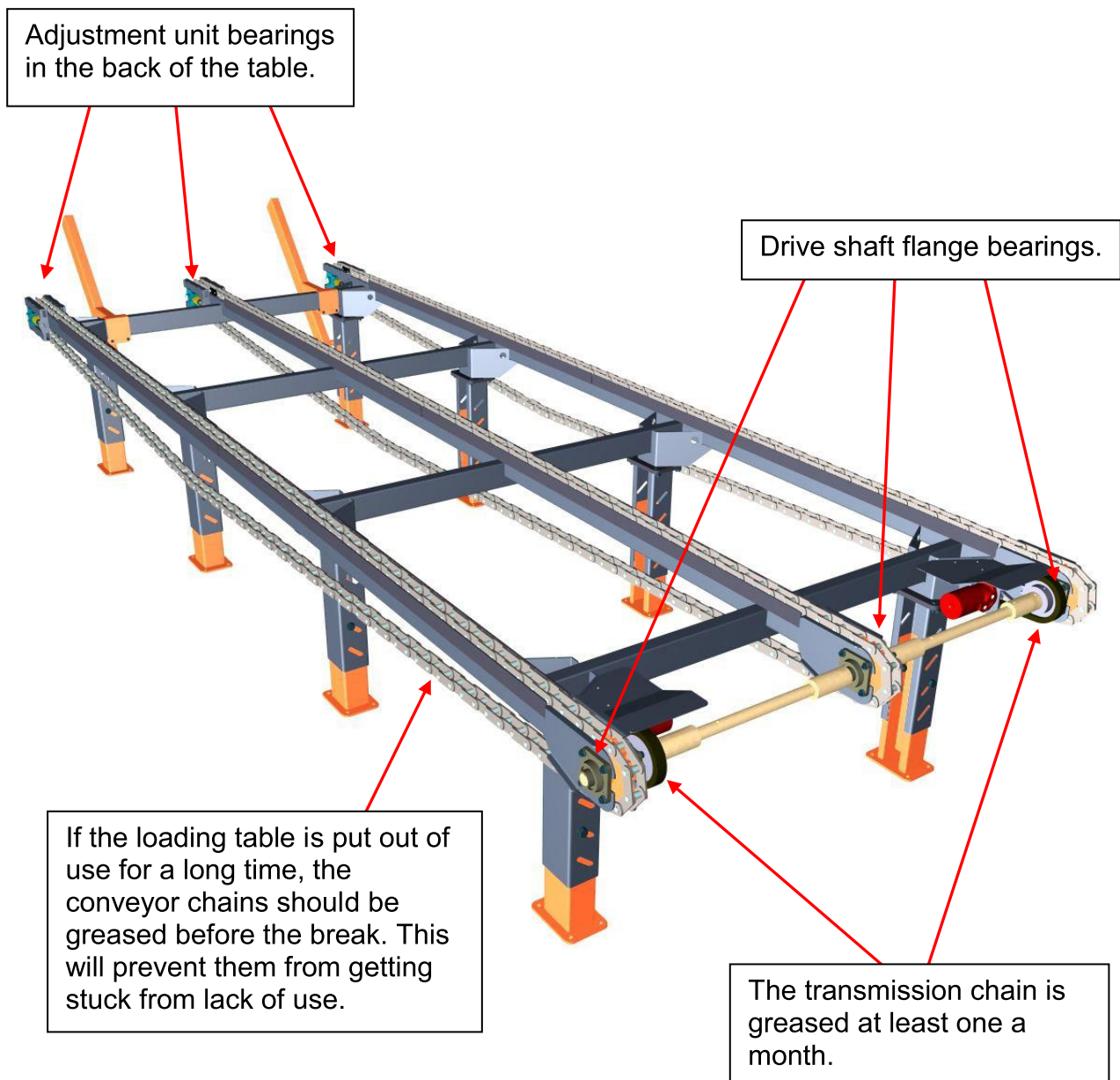

Loading table 44100 greasing locations

In normal daily use, the machine should be greased at least once a month.

